

Model NO: SS1419R10

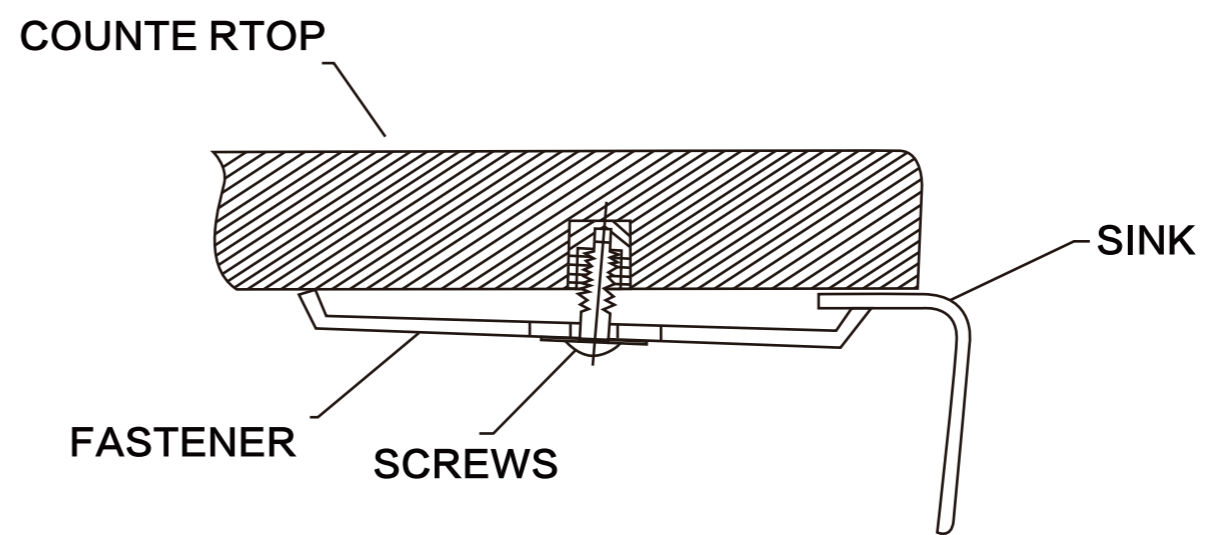
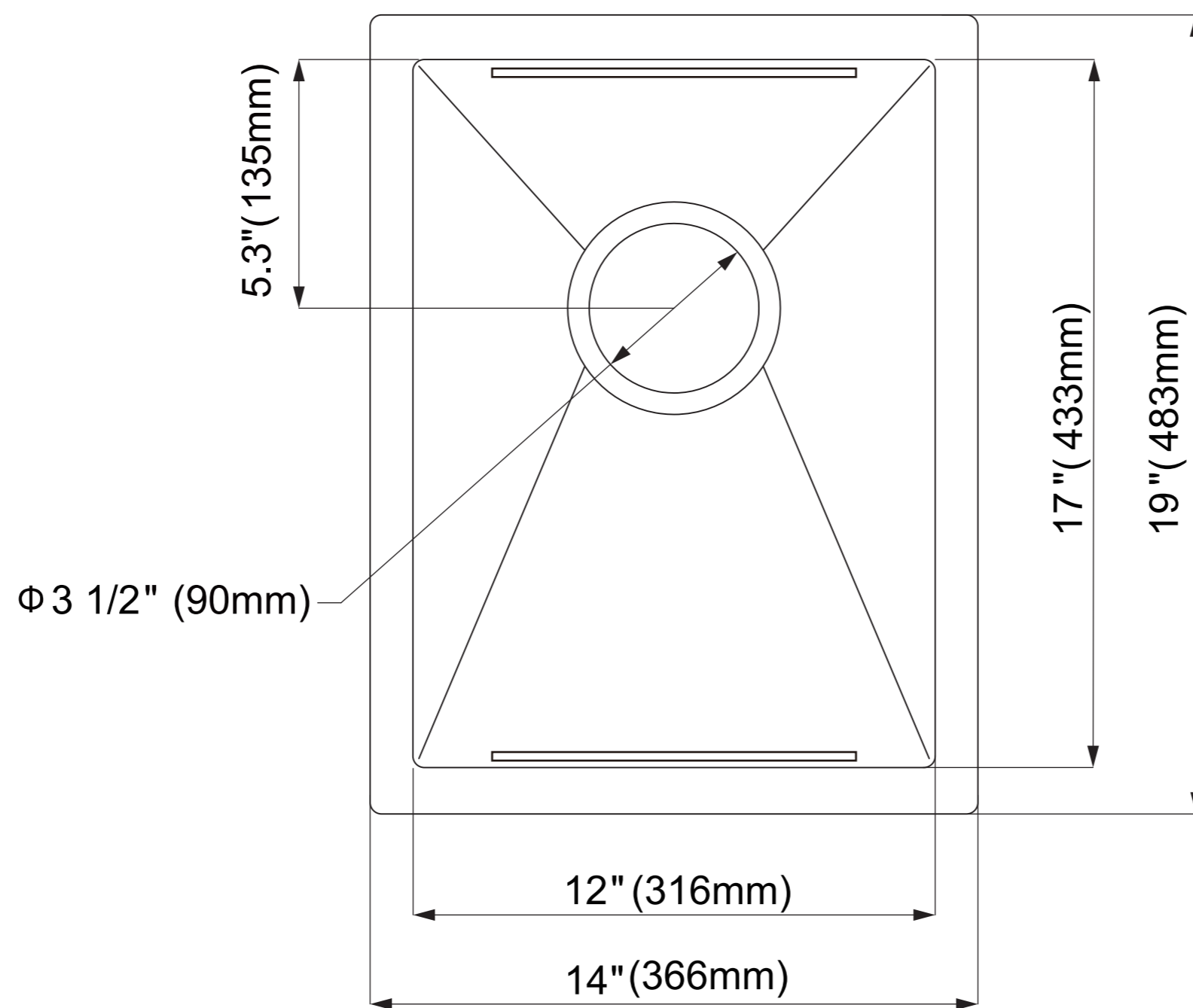

Any questions.
PLS feel free to contact us.
We'll reply you within 24 hours.

Please tear perforated edge for zero / flushed reveal $12" \times 17" (316\text{mm} \times 433\text{mm})$
Please use outer edge for positive reveal $3/8"$ $325\text{mm} \times 442\text{mm}$

NOTE: Cutout template is provided as a guide ONLY and must be checked against actual sink to verify correct fit.

Hole size: 325mm*442mm Fillet: R10 (1:1) Applicable model : SS1419R10